

CABINETS

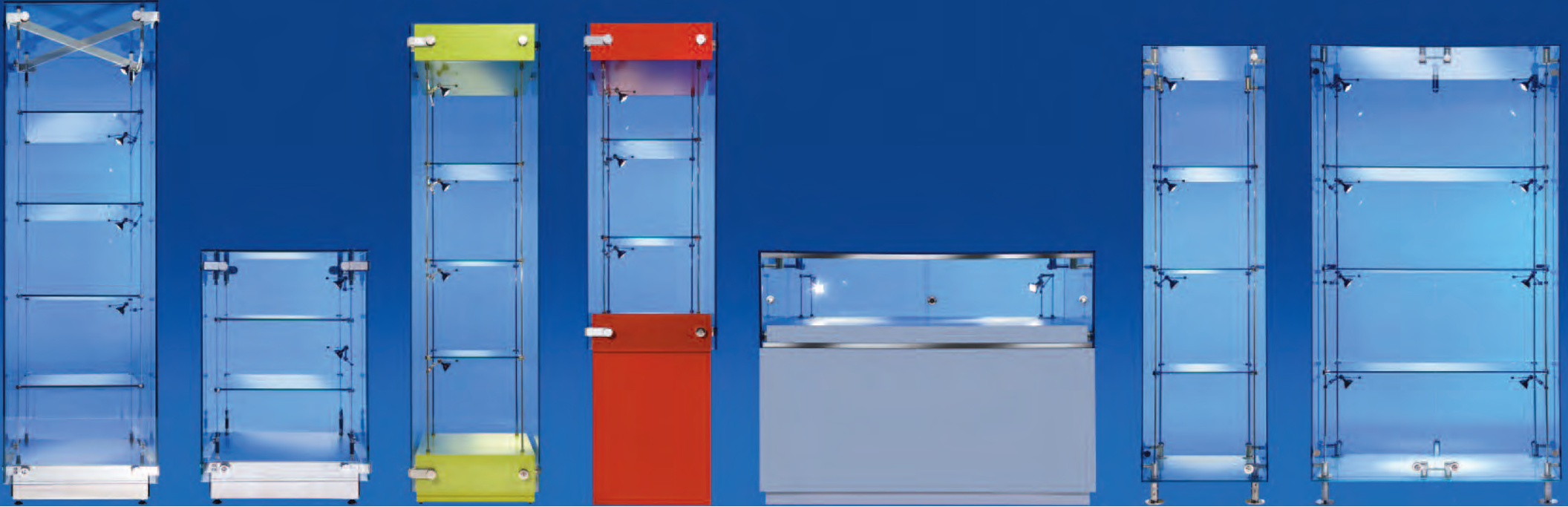

INNOVATIVE
AND UNIQUE
DISPLAY CABINETS

SSG001 TALL

SSG001 LOW

WG001

WG002

WG003

SSG002 500

SSG002 1000

CABI

NETS

CABINETS

Design, innovation, attention to detail and high quality manufacture are the core values of the Shopkit Group.

In this brochure Shopkit presents it's standard range of cabinets. Cabinets that add value and enhance the presentation of any product or valuable artifact that they may contain. This range of cabinets will satisfy most requirements as it offers a comprehensive range of sizes, colours and materials, but should slight variations or complete bespoke designs be required, Shopkit offer a design and manufacturing service to meet this need.



CABINETS

01 Contents

02 SSG001 (Tall)

03 SSG002 (Low)

04 SSG002 (500)

05 SSG002 (1000)

06 CMC001

07 CMC002

08 WG001

09 WG002

10 WG003

11 Bespoke

12 Components



SSG001 (Tall)

Stainless steel and glass illuminated cabinet

A unique and finely detailed display cabinet standing 2200mm high by 650mm square in plan. Using 10mm toughened glass as the support structure, a stainless steel cross frame with integral patch fittings and hinge is used to secure the glass at the top. At the base a folded stainless steel plinth in a brushed finish locates over a base frame with integral patch fittings, hinge, adjustable feet and fixing point for the lighting transformer. The base assembly secures the glass at the bottom with dual purpose lighting/support cables tensioned between the top and bottom frames. This provides an efficient method of both supporting shelves and lighting. The power supply is connected through the base unit to the tensioned cables by power feed cables and connectors. Shelves are attached to the cables using polished stainless steel shelf grips. Lighting units are slotted at each end and are secured to the cables by hand tightening a knurled screw on to the cables. The cabinet is locked at the base using the option of a removable threaded stainless steel disc at the top or a dummy disc fixed to the door.

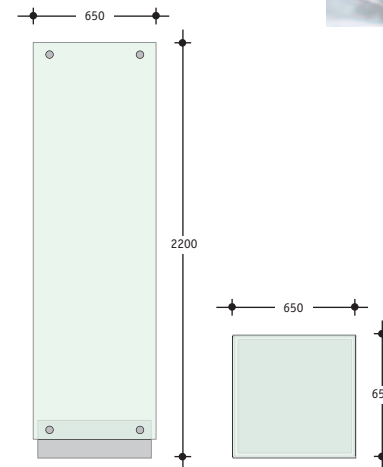
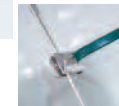
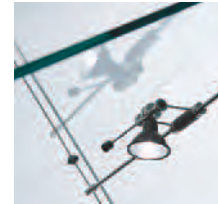

SSG001A x 1

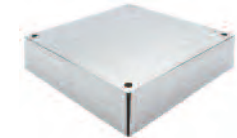

SSG001B x 1

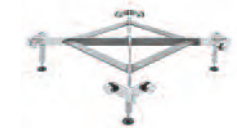

SSG001C x 1

Transformer
with Power
Feeds x 1

SSG001G x 4



TZ1 530 x 4



SSGC2 x 1



3.17 x 16

SSG001 (Low)

Stainless steel and glass illuminated cabinet

This cabinet, 1000mm high by 650mm square in plan, is constructed in the same manner as the tall cabinet with the exception of the top fixings. In order to allow a clear and unobstructed view of the interior the top cross frame has been replaced by individual corner patch fittings and hinge unit.

The cabinet is locked at the base using the option of a removable threaded stainless steel disc at the top or a dummy disc fixed to the door.

Special sizes

Both SSG 001 Tall and SSG 001 Low can be manufactured to meet individual requirements.

Components

All components are available individually with the glass being sourced separately. The structural glass is 10mm toughened. The door is 8mm toughened and the shelves 8mm toughened.

Installation

Shopkit can deliver and install these cabinets. Quotations will be supplied on request.

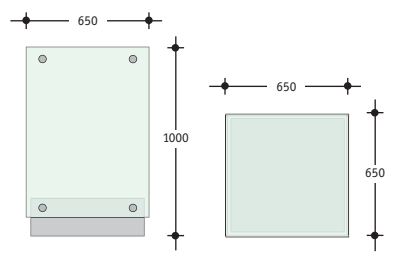

-  SSG001D x 3
-  SSG001E x 1
-  SSG001B x 1
-  SSG001C x 1
-  Transformer with Power Feeds x 1
-  SSG001F x 4
-  TZ1 530 x 2
-  SSGC2 x 1
-  3.17 x 8

SSG002 (500)

Mirror polished stainless steel or satin anodised aluminium and glass illuminated cabinet

Refined detailing and minimalist construction define this elegant display cabinet. The satin anodised or mirror polished stainless steel top corner fittings use a three-way connector to secure side and top panels, while the hinged side uses a two-way connector securing the top to the side. The base connectors use three and two-way connectors as at the top, but also have an isolated leg assembly with adjustable feet and a connection point for supplying power to the integral lights. The base of the cabinet is 10mm toughened glass silk screened white to the underside so shielding the view of the transformer and supporting stainless steel sling secured underneath. This attention to detail results in a simple design where the product on display has no distracting elements.

The lighting arms and shelf supports can be positioned as required on the chromed brass tensioned rods.

Standard units have one lock at the base with the option of a removable aluminium disc at the top or a dummy disc fixed to the door.

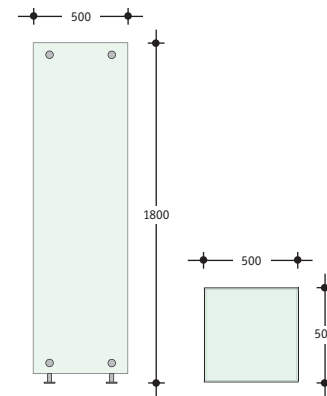

SSG002A x 1



SSG002B x 3



SSG002C x 1



SSG002D x 2



SSG002E x 1



SSG002G x 2



SSG002K x 2



TZ1 400R x 4



SSGC2 x 1

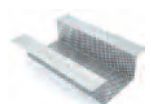

SSG002J x 4

ER4C/SAA x 12
(ER4C/CB)Transformer
with Power
Feeds x 1

SSG002H x 1

SSG002 (1000)

Mirror polished stainless steel or satin anodised aluminium and glass illuminated cabinet

All details to this cabinet are essentially the same as SSG 002, but being 1000mm wide there are two doors with hinges and locks and additional lighting with lights being supplied to the right and left hand sides.

Special sizes



Both SSG002 500 and SSG002 1000 can be manufactured to meet individual requirements.

Components

All components are available individually with the glass being sourced separately. The structural glass is 6mm toughened, the door is 6mm toughened and the base 10mm toughened with the underside silk screened white.

Installation

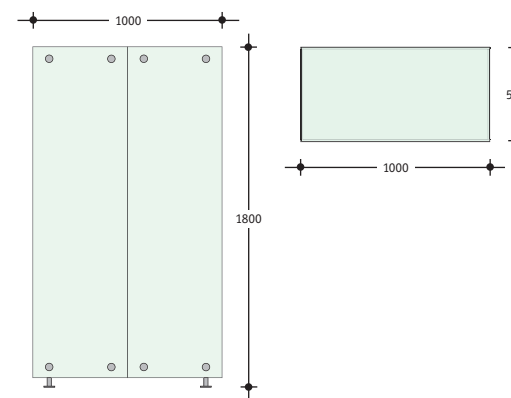
Shopkit can deliver and install these cabinets. Quotations will be supplied on request.

SSG002A x 4



SSG002B x 2



SSG002C x 2



SSG002D x 2



SSG002G x 4



SSG002K x 2



SSG002F x 1



SSG002L x 1



TZ1 400R x 8



SSGC2 x 2



SSG002J x 4



ER4C/SAA x 12
(ER4C/CB)



Transformer
with Power
Feeds x 1



SSG002H x 1

Cable Cabinets

As a leading designer of systems for display merchandising Shopkit offer this well proven and unique system of satin anodised aluminium components enabling glass cabinets to be supported on tensioned cables. The cabinets have adjustable shelves secured to the cables or rods using satin anodised shelf grips.

Cabinets can be supported from cables fixed in any combination from the wall, floor or ceiling. Shopkit also supplies standard or special steel frames to support the tensioned cables.

CMC001

(between cables)

Available in two sizes as standard - 1200mm high x 304 deep x 600 wide and 1200m high x 304 deep x 1175 wide.

The cabinets are constructed from 8mm toughened glass using satin anodised aluminium components. The cabinet is assembled free of the cables and once completed, secured in the required position using allen screws which trap the cable into the slotted bosses on the sides of the cabinet. Doors are hung on chromed brass hinges and

lock onto a central locking plate with a lock to each door. Shelves are supported on chromed brass rods which can be powered by power feeds from a remote transformer which can be concealed in a ceiling or wall. Shopkit will advise on the most suitable option. Both cabinets are lockable.

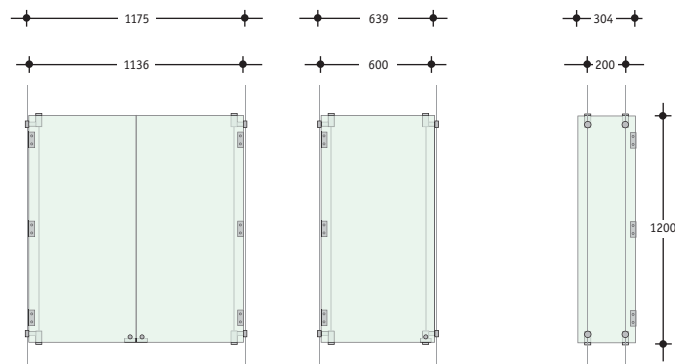

-  **CMC001A** x 4
-  **CMC001B** x 4
-  **CMC001C** x 2
-  **CMC001D** x 1
-  **SC3D** x 1
-  **SC4** x 6
-  **TZ1 200R** x 4
-  **ER4C/SAA** x 12
(ER4C/CB)
-  **Transformer**
with power feeds x 1

CMC002

(around cables)

Available in two sizes as standard;
1200mm high x 304 deep x 1279 wide and
1200mm high x 304 deep x 600 wide.

The cabinets are constructed from 8mm toughened glass using satin anodised aluminium components. The cabinet is assembled around the tensioned cables. Both cabinets come with three shelves. Lighting is not available in this unit as standard, but Shopkit can advise on bespoke lighting solutions. Both cabinets are lockable.

Special sizes

CMC 001 and CMC 002 can be manufactured to individual requirements.

Components

All fittings can be supplied individually.
Glass is 8mm toughened.

Installation

Shopkit can deliver and install these cabinets. Quotations will be supplied on request.



CMC002A x 4



CMC002B x 4



SC3S x 1



SC4 x 3



3.17 x 12

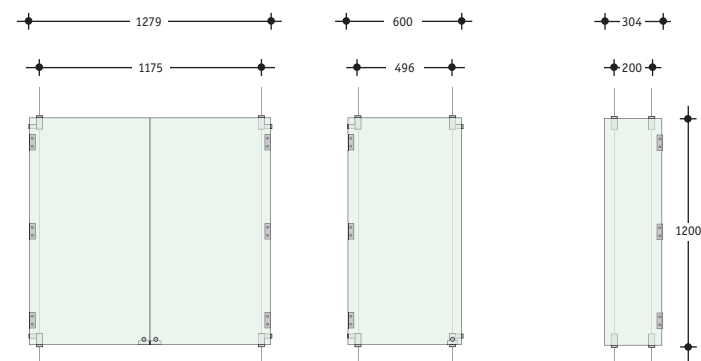

WG001/2/3

Wood and glass cabinets with polished stainless steel fittings.

Shopkit offers three standard styles of cabinet (WG 001, WG 002, WG 003) using polished stainless steel components to secure the glass to the timber cabinets.

WG001

Supplied as standard 2100mm high x 550 x 550. Timber soffit box 150mm high, base plinth 200mm high. Complete with 3 glass shelves, 4 lights and transformer.

Special sizes

Cabinet bases and tops are available in a choice of colours, plastic laminates, as well as timber veneers.

Components

All fittings can be supplied individually. Glass is 8mm toughened.

Installation

Shopkit can deliver and install these cabinets. Quotations will be supplied on request.

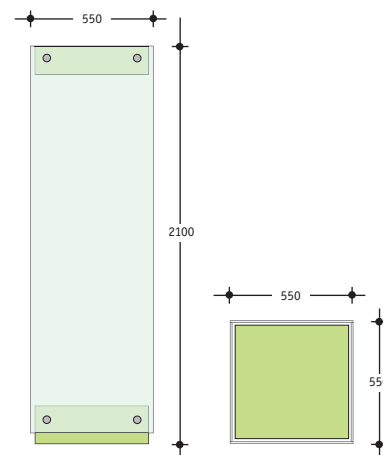
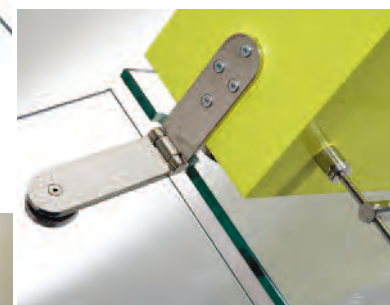
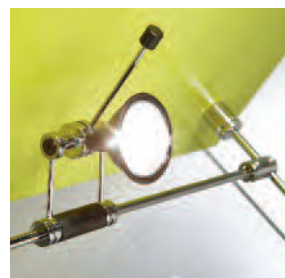

C1 x 13



C2 x 1



WG001C x 4



C3 x 2



TZ1 400R x 4



ER4C/SAA x 12
(ER4C/CB)



Transformer
with power
feeds x 1



WG001A



WG001B

WG002

Supplied as standard 2100mm high x 550 x 550. Timber soffit box 150mm high, base plinth 800mm high complete with 2 x glass shelves, 3 x lights and transformer.

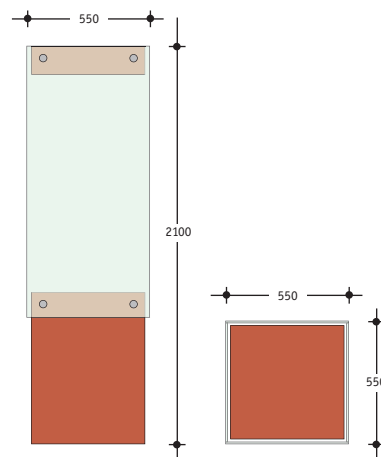

WG003

Supplied as standard 1000mm high x 600 x 1200. Height inside glass top 300mm. Sliding doors set in polished aluminium track, with the top track bonded to the glass top and a centrally positioned lock. The base unit is supplied with locking doors and a cupboard with 1 shelf.

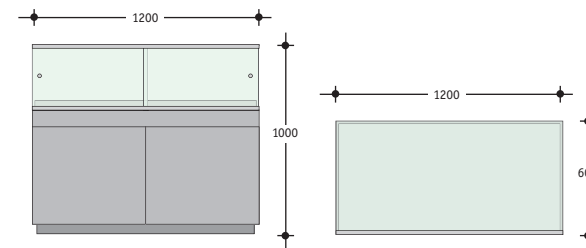

-  **C1 x 6**
-  **C8 x 1**
-  **WMG2 x 2**
-  **WMG3 x 2**
-  **C6TT x 1**
-  **C6BT x 1**
-  **C7 x 2**
-  **TZ18 305 x 2**
-  **Transformer with power feeds x 1**

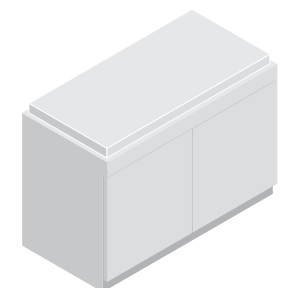

WG003A

Bespoke

Shopkit can design, manufacture and install many different styles of bespoke counters and cabinetry in different materials, with integral low-voltage lighting to suit all types of applications. Here are just a few completed projects.



Components



SSG001A



SSG001E



SSG002A



SSG002E



SC3C

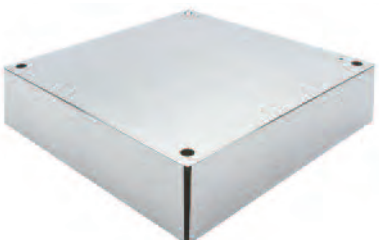

SSG001B



SSG001G



SSG002B



SSG002G



SC3D



SSG001C



SSG001F



SSG002C



SSG002K



SSG002F



SSG001D



SSG2



SSG002D



ER4CCB



SSG002L



3.17



CMC002A



C1



WG001C - WG002C

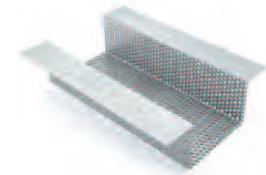

SSG002H



SC4 Satin



CMC002B



C2



WMG2



Transformer



CMC001A



CMC001D



C3



WMG3



TZ1 200C, 200R, 400C, 400R, 530C



CMC001B



C8



C7



C6TT + C6BT



TZ18 305

CABIN

ETS

SHOPKIT SPAIN

Gran Via Hortaleza, 66 . 28043 Madrid . Spain

Tel: +34 91 300 57 20

Fax: +34 91 300 57 21

email: info@shopkit.com.es

SHOPKIT FRANCE

Hubert II . 19, av. Georges Pompidou . FR-40130 Capbreton . France

Tel: +33 562 39 57 22

Fax: +33 05 58 72 07 49

email: info@shopkit.fr

DESIGNPLUS

P.O. Box 789 . Al Khobar . 31952 . Kingdom of Saudi-Arabia

Tel: +966 (0)3 882 9252

Fax: +966 (0)3 882 9251

email: info@designplus-sa.com web: designplus-sa.com

B&N INDUSTRIES

1409 Chapin Ave . 2nd Floor . Burlingame . California 94010 . U.S.A

Tel: +1 800 350 4127

Fax: +1 650 393 2436

email: info@bnind.com web: www.bnind.com

DAVIES GROUP

Showroom No. 4 . Opp. Al Khaleej National School . Al Garhoud . Dubai . UAE

Tel: +9714 2828528

Fax: +9714 2828328

email: info@daviesgroupuae.com

LOGOGRAFICA INDUSTRIAL, LDA

Rua C Lote 73-A . Vale do Forno . 2675 Odivelas . Portugal

Tel: +35121 931 2061

Fax: +35121 931 2045

email: info@logografica.pt web: www.logografica.pt

CABINETS
INNOVATIVE
AND UNIQUE
DISPLAY CABINETS

SHOPKIT GROUP LIMITED

100 Cecil Street · North Watford · Hertfordshire WD24 5AD · England

Tel: +44 (0)1923 818282 Fax: +44 (0)1923 818280 email: sales@shopkit.com web: www.shopkit.com

SHOPKIT EXPORT LIMITED

100 Cecil Street · North Watford · Hertfordshire WD24 5AD · England

Tel: +44 (0)1923 818282 Fax: +44 (0)1923 818280 email: sales@shopkit.com web: www.shopkit.com

SHOPKIT GmbH

Adlerstrase. 9 · 40211 Düsseldorf · Germany

Fon: +49(0)211/38 69 6-0 Fax: +49(0)211/38 69 6-24 email: info@shopkit.de web: www.shopkit.de